

MAiNNAV International Corp.

11F, 293-1, Sec. 1, Zhongshan Rd., Banqiao City, Taipei 220, Taiwan, R.O.C. Tel: +886 2 8953-6616

Web: www.mainnav.com E-mail: info@mainnav.com Fax: +886 2 8951-8531

MM-520 使用手冊

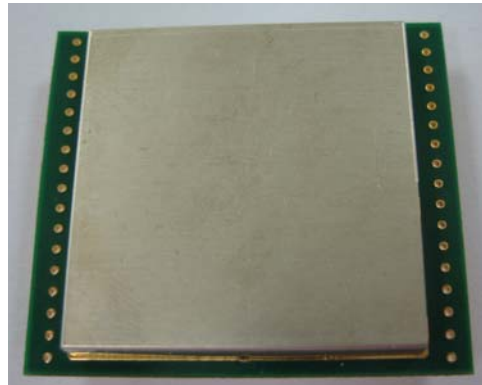

MAINNAV International Corp.

11F, 293-1, Sec. 1, Zhongshan Rd., Banqiao City, Taipei 220, Taiwan, R.O.C. Tel: +886 2 8953-6616

Web: www.mainnav.com E-mail: info@mainnav.com Fax: +886 2 8951-8531

目 錄

● 產品簡介	2
● 產品特性	2
● 產品規格	2
● 環境因素	2
● 電氣特性	3
● 操作性能	3
● 定位精度	3
● 動態規格	3
● 硬體介面	4
● 操作特性	4
● 軟體介面	5

MAINNAV International Corp.

11F, 293-1, Sec. 1, Zhongshan Rd., Banqiao City, Taipei 220, Taiwan, R.O.C. Tel: +886 2 8953-6616

Web: www.mainnav.com E-mail: info@mainnav.com Fax: +886 2 8951-8531

產品簡介

MM-520 是一款完整功能的 GPS 模組，它是以 SiRF Star III 的單晶片核心設計提供給 GPS 應用產品的最佳選擇，提供了目前世界上民用導航所需求的最高靈敏度的性能，應用在車用導航、測繪、保全、農業上有著卓越的表現。它的高感度特性可以在任何惡劣的環境下進行定位的作業，對於應用在對 GPS 需求的產品上提供了優越的性能，內建鋰電池可記憶最終定位資訊，同時追蹤 20 顆衛星並顯示 12 顆衛星信息，TTL 及 RS-232 的電路訊號輸出讓您在規劃上提供便捷的資訊輸出，”TTFF”(Time to First Fix)優越的性能讓您在訊號微弱的地方也能快速定位，獨家的”Trickle Power”省電模式以及在所需的時間執行功能(Push-to fix)在關閉狀態下開啟的即時定位功能，提供使用者必須獲得的資訊提供您整合各種應用。

一、產品特性：

MM-520 提供您完整的應用便利性，讓您後段開發應用上獲得強大的執行效力。

- 1、MM-520 採用 SiRF Star III 單晶片組設計而成的衛星定位模組，提供您所需求的軟體。
- 2、高感度的定位能力提供了可追蹤 20 顆衛星並鎖定 12 顆衛星顯示。
- 3、支援偏差修正功能(RTCM)時定位精準度至 1-5 米。
- 4、標準輸出介面規格讓您規劃更便利。
- 5、內建 WAAS 及 EGNOS 支援同步衛星接收。

二、產品規格：

- 1、外觀尺寸：44 mm(L)×35 mm(W)×8.5 mm(H)
- 2、實體重量：25 公克

三、環境因素：

- 1、操作溫度：-40°C~80°C
- 2、儲存溫度：-55°C~100°C

MAINNAV International Corp.

11F, 293-1, Sec. 1, Zhongshan Rd., Banqiao City, Taipei 220, Taiwan, R.O.C. Tel: +886 2 8953-6616

Web: www.mainnav.com E-mail: info@mainnav.com Fax: +886 2 8951-8531

四、電氣特性：

1、輸入電壓：DC-5V

五、操作性能：

1、靈敏度：-159dBm

2、捕獲衛星數量：20 顆有效衛星。

3、鎖定衛星數量：12 顆

4、更新速率：1/秒

5、定位資料更新：0.1/秒

6、瞬間定位：3/秒

7、熱開機：6/秒(平均值)

8、暖開機：38/秒(平均值)

9、冷開機：42/秒(平均值)

六、定位精度：

無偏差修正訊號 < 10 米 2D 模式，速度：0.1/秒，時間：1/微秒(衛星時間)

有偏差修正訊號接收(WAAS&EGNOS) < 1~5 米，速度：0.05/秒

七、動態規格：：

高度: 18,000 米 (60,000 英尺)

速率: 515 米/秒 (1000 knots)

爆衝: 20 米/秒

加速度: 4 G

介面

(1)RS-232 ,傳輸數率9600

(2)NMEA 0183 Version 2.2 ASCII output (GPGGA, GPGLL, GPGSA, GPGSV, GPRMC, GPVTG).

(3)Real-time Differential Correction input (RTCM SC-104 message types 1, 5 and 9).偏差信號接收(選項)

(4)SiRF 通訊協定 (選項)

MAINNAV International Corp.

11F, 293-1, Sec. 1, Zhongshan Rd., Banqiao City, Taipei 220, Taiwan, R.O.C. Tel: +886 2 8953-6616

Web: www.mainnav.com E-mail: info@mainnav.com Fax: +886 2 8951-8531

八、硬體介面：

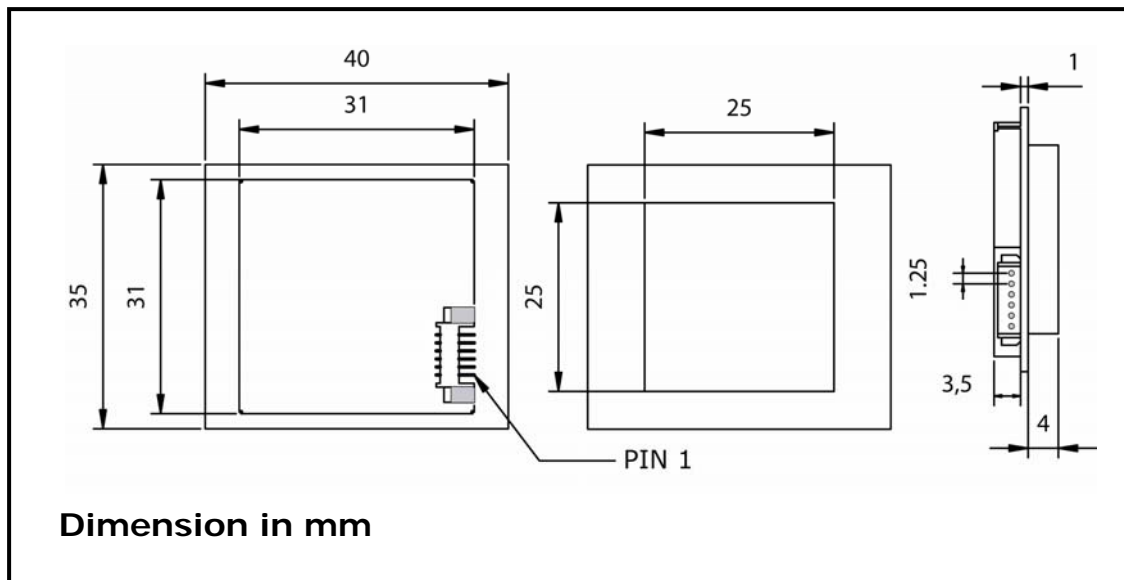

PIN Number	Name	Description
1	TTL TX	TTL data output
2	Ground	Ground
3	TTL RX	TTL data input
4	RS232 RX	RS232 data input
5	RS232 TX	RS232 data output
6	VCC	5Vdc

九、操作特性：

當您完整的將規格上所敘述的 PIN 接至你所應用的產品上時，它便開始進行接收衛星接收譯碼的功能，在正常的操作下，首次定位(Cold start)所耗費的時間為 42/秒完成定位，在定位成功之後，便開始經由 TTL 或 RS-232 的介面傳輸所接收到的資料至您所接入的設備或儀器上，此後在 4 小時之內重新定位為 38 秒(暖開機)與 1 小時內開機定位 6 秒(熱開機)模式，在 -159dBm 的高感度的性能下，讓您在正常與惡劣環境下正確迅速的捕捉衛星定位訊息，內建的鋰電池(記憶電池)提供了 230h/r 的儲存電力，9.5 天(平均值)之內將不會回到初始化狀態(Cold Start)，以提供使用者快速定位的性能需求。

MAINNAV International Corp.

11F, 293-1, Sec. 1, Zhongshan Rd., Banqiao City, Taipei 220, Taiwan, R.O.C. Tel: +886 2 8953-6616

Web: www.mainnav.com E-mail: info@mainnav.com Fax: +886 2 8951-8531

十、軟體介面(NMEA 0183V2.2)

MM-520 所採用的 SiRF Star III 晶片組所內建的 GPS 通訊協議所採用的 SiRF Star III 晶片組所內建的 GPS 通訊協議標準 NMEA0183V2.2 版輸出, 傳輸速率為 4800 傳輸速率為 4800 輸出(速率可依需求修正)

NMEA Record	Description
GPGGA	Globe positioning system fixed data
GPGLL	Geographic position- latitude/longitude
GPGSA	GNSS DOP and active satellites
GPGSV	GNSS satellites in view
GPRMC	Recommended minimum specific GNSS data
GPVTG	Course over ground and ground speed

各協議代碼定義：

GPS Fix Data (GGA)

\$GPGGA,161229.487,3723.2475,N,12158.3416,W,1,07,1.0,9.0,M, , , ,0000*18

GGA Data Format

Name	Example	Units	Description
Message ID	\$GPGGA		GGA protocol header
UTC Time	161229.487		Hhmmss.sss
Latitude	3723.2475		ddmm.mmmm
N/S Indicator	N		N=north or S=south
Longitude	12158.3416		dddmm.mmmm
E/W Indicator	W		E=east or W=west
Position Indicator	Fix 1		See Table 5-3
Satellites Used	07		Range 0 to 12
HDOP	1.0		Horizontal Dilution of Precision
MSL Altitude	9.0	Meters	
Units	M	Meters	
Geoid Separation		Meters	
Units	M	Meters	
Age of Diff. Corr.		second	Null fields when DGPS is not used
Diff. Ref. Station ID	0000		
Checksum	*18		
<CR> <LF>			End of message termination

MAINNAV International Corp.

11F, 293-1, Sec. 1, Zhongshan Rd., Banqiao City, Taipei 220, Taiwan, R.O.C. Tel:+886 2 8953-6616

Web:www.mainnav.com E-mail:info@mainnav.com Fax:+886 2 8951-8531

Position Fix Indicator

Value	Description
0	0 Fix not available or invalid
1	GPS SPS Mode, fix valid
2	Differential GPS, SPS Mode, fix valid
3	GPS PPS Mode, fix valid

Geographic Position with Latitude/Longitude (GLL)

\$GPGLL,3723.2475,N,12158.3416,W,161229.487,A*2C

GLL Data Format

Name	Example	Units	Description
Message ID	\$GPGLL		GLL protocol header
Latitude	3723.2475		ddmm.mmmm
N/S Indicator	N		N=north or S=south
Longitude	12158.3416		dddmm.mmmm
E/W Indicator	W		E=east or W=west
UTC Position	161229.487		hhmmss.sss
Status	A		A=data valid or V=data not valid
Checksum	*2C		
<CR> <LF>			End of message termination

GNSS DOP and Active Satellites (GSA)

GPGSA,A,3,07,02,26,27,09,04,15, , , , , 1.8,1.0,1.5*33

GSA Data Format

Name	Example	Units	Description
Message ID	\$GPGSA		GSA protocol header
Mode 1	A		See Table 5-6
Mode 2	3		See Table 5-7
Satellite Used (1)	07		Sv on Channel 1
Satellite Used (1)	02		Sv on Channel 2
.....		
Satellite Used			Sv on Channel 12
PDOP	1.8		Position Dilution of Precision
HDOP	1.0		Horizontal Dilution of Precision
VDOP	1.5		Vertical Dilution of Precision
Checksum	*33		
<CR> <LF>			End of message termination

MAINNAV International Corp.

11F, 293-1, Sec. 1, Zhongshan Rd., Banqiao City, Taipei 220, Taiwan, R.O.C. Tel: +886 2 8953-6616

Web: www.mainnav.com E-mail: info@mainnav.com Fax: +886 2 8951-8531

1. Satellite used in solution.

Mode 1

Value	Description
M	Manual—forced to operate in 2D or 3D mode
A	2D Automatic—allowed to automatically switch 2D/3D

Mode 2

Value	Description
1	Fix Not Available
2	2D
3	3D

GNSS Satellites in View (GSV)

\$GPGSV,2,1,07,07,79,048,42,02,51,062,43,26,36,256,42,27,27,138,42*71

\$GPGSV,2,2,07,09,23,313,42,04,19,159,41,15,12,041,42*41

GSV Data Format

Name	Example	Units	Description
Message ID	\$GPGSV		GSV protocol header
Number of Messages	2		Range 1 to 3
Message Number	1		Range 1 to 3
Satellites in View	07		Range 1 to 12
Satellite ID	07		Channel 1 (Range 1 to 32)
Elevation	79	degrees	Channel 1 (Maximum 90)
Azimuth	048	degrees	Channel 1 (True, Range 0 to 359)
SNR (C/No)	42	dBHz	Range 0 to 99, null when not tracking
....		
Satellite ID	27		Channel 4 (Range 1 to 32)
Elevation	27	degrees	Channel 4 (Maximum 90)
Azimuth	138	degrees	Channel 4 (True, Range 0 to 359)
SNR (C/No)	42	dBHz	Range 0 to 99, null when not tracking
Checksum	*71		
<CR> <LF>			End of message termination

MAINNAV International Corp.

11F, 293-1, Sec. 1, Zhongshan Rd., Banqiao City, Taipei 220, Taiwan, R.O.C. Tel: +886 2 8953-6616

Web: www.mainnav.com E-mail: info@mainnav.com Fax: +886 2 8951-8531

Recommended Minimum Specific GNSS Data (RMC)

\$GPRMC,161229.487,A,3723.2475,N,12158.3416,W,0.13,309.62,120598, ,*10

RMC Data Format

Name	Example	Units	Description
Message ID	\$GPRMC		RMC protocol header
UTC Time	161229.487		hhmmss.sss
Status	A		A=data valid or V=data not valid
Latitude	3723.2475		ddmm.mmmm
N/S Indicator	N		N=north or S=south
Longitude	12158.3416		dddmm.mmmm
E/W Indicator	W		E=east or W=west
Speed Over Ground	0.13	Knots	
Course Over Ground	309.62	Degrees	True
Date	120598		Ddmyyy
Magnetic Variation (1)		Degrees	E=east or W=west
Checksum	*10		
<CR> <LF>			End of message termination

SiRF Technology Inc. does not support magnetic declination. All “course over ground” data are geodetic WGS84 directions.

Course Over Ground and Ground Speed (VTG)

\$GPVTG,309.62,T, ,M,0.13,N,0.2,K*6E

VTG Data Format

Name	Example	Units	Description
Message ID	\$GPVTG		VTG protocol header
Course	309.62	Degrees	Measured heading
Reference	T		True
Course		Degrees	Measured heading
Reference	M		Magnetic (1)
Speed	0.13	Knots	Measured horizontal speed
Units	N		Knots
Speed	0.2	Km/hr	Measured horizontal speed
Units	K		Kilometers per hour
Checksum	*6E		
<CR> <LF>			End of message termination

MAiNNAV International Corp.

11F, 293-1, Sec. 1, Zhongshan Rd., Banqiao City, Taipei 220, Taiwan, R.O.C. Tel: +886 2 8953-6616

Web: www.mainnav.com E-mail: info@mainnav.com Fax: +886 2 8951-8531

SiRF Technology Inc. does not support magnetic declination. All “course over ground” data are geodetic WGS84 directions.

RTCM Received Data

The default communication parameters for DGPS Input are 9600 baud, 8 data bits, stop bit, and no parity. Position accuracy of less than 5 meters can be achieved with the GPS-27 by using Differential GPS (DGPS) real-time pseudo-range correction data in RTCM SC-104 format, with message types 1, 5, or 9. As using DGPS receiver with different communication parameters, GPS-27 may decode the data correctly to generate accurate messages and save them in battery-back SRAM for later computing.